



The SB-2500B Shuttle Buggy® material transfer vehicle can store and transfer hot-mixed asphalt material from a truck to a paver for continuous paving. A patented antisegregation auger remixes materials just before they are delivered to the asphalt paver. The 25-ton (22.7 MT) surge capacity of the SB-2500B allows trucks to unload material immediately and return to the asphalt plant. Options include the windrow pickup head and the road widener attachment.

SB-2500B SPECIFICATIONS

ENGINE:

John Deere™ 6081 AF, 6-cylinder diesel engine, 275 HP (206 kw) @ 1,900 rpm. Engine instrumentation includes tach/hour meter, oil pressure, voltage and emergency shutdown system. Easy access to oil cooler/radiator.

OPERATOR'S STATION:

Operator positions on both sides. Control panel pivots for use from either station allowing for same-lane or adjacent-lane operation from either side. One-piece hydraulically-raisable platform allows easy access to engine, pumps and motors. Inside turning radius 26'6" (8.1 m).

GROUND DRIVE:

All hydrostatic for continuously variable speed control with two speed ranges. Electric-over-hydraulic shift between working and transport ranges. Maximum speed (working range) 3.0 mph (4.8 kph). Maximum speed (travel range) 9 mph (14.5 kph).

TIRES:

Large, high-flotation - 21:00 x 25" (53.3 m x 635 mm).

ELECTRICAL SYSTEM:

Standard system includes heavy-duty alternator, battery, and circuit breaker protection of all systems.

FUME EXTRACTION SYSTEM:

Two blowers. Fold-down 10" (254 mm) exhaust pipes.

SLAT CONVEYORS

TRUCK UNLOADING (C-1):

High-capacity truck unloading system with low deck height, 9'2" (2.8 m) side truck opening and 29" (737 mm) o.d. x 7" (178 mm) deep Ni-Hard segmented converging auger for quick material flow. Conveyor has weld-on flights 5/8" (16 mm) thick, 7" (178 mm) wide x 58" (1,473 mm) long. Ni-Hard liner plates are removable. Power dump front hopper has a vibrator on the bottom that helps keep material moving. Fixed push roller is standard. Conveyor capacity is rated at 1,000 TPH (907 MTPH).

SURGE BIN (C-2):

Unloads the surge bin with a multi-pitch 29" (737 mm) o.d. x 7" (178 mm) deep Ni-Hard segmented anti-segregation auger in the hopper. Conveyor system has weld-on flights 5/8" (16 mm) thick, 7" (178 mm) wide x dual 16" (406 mm) long. Liner plates are Ni-Hard and removable. Conveyor capacity is 600 TPH (544 MTPH).

PAVER LOADING (C-3):

Conveyor swings 55 degrees to either side of center. Maximum conveyor discharge height is 12' 2" (3.7 m) from ground level. Conveyor flights welded to the chain are 5/8" (16 mm) thick, 3" (76.2 mm) wide and 30" (762 mm) long. Conveyor has bolted 1/2" (12.7 mm) T-1 replaceable floor plates and doors. C-2 and C-3 conveyors have on/off controls that are interlocked. Conveyor capacity is 600 TPH (544 MTPH).

HOPPER INSERT:

A mass-flow paver hopper insert is used to increase the hopper capacity of a conventional paver when used with the SB-2500B.

CAPACITIES:

Fuel tank.....	150 gal (568 l)
Hopper.....	25 tons (22.7 MT)
material.....	120 lbs/cu ft (1,922 kg/cu m)

WEIGHTS:

Shipping weight.....	79,300+ lbs (35,970 kg)
----------------------	-------------------------

OPTIONS:

- Spray down system
- Hydraulic generator set
- Windrow attachment
- Road widener attachment

ROADTEC an Astec company

800 MANUFACTURERS ROAD • CHATTANOOGA, TN 37405 • TELEPHONE 423-265-0600 • FAX 423-267-7104

© 2001 Roadtec

- A 55'-9" (16.99m)
- B 53'-5" (16.28m)
- C 19'-9" (6.02m)
- D 14'-4" (4.37m)
- E 12'-0" (3.66m)
- F 5'-10" (1.78m)
- G 12'-2" (3.71m)
- H 16'-0" (4.88m)

- J 9'-3" (2.82m)
- K 5'-9" (1.75m)
- L 5'-5" (1.65m)
- M 10'-4" (3.15m)

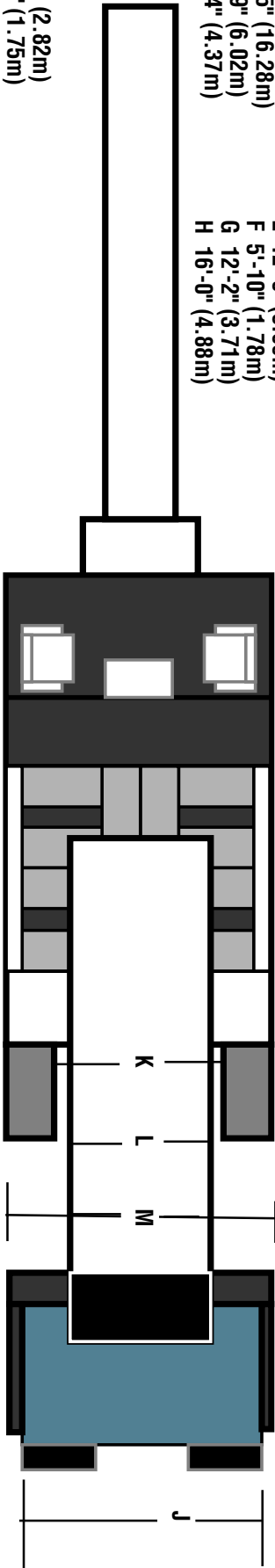

Exhaust stack folds down for transport

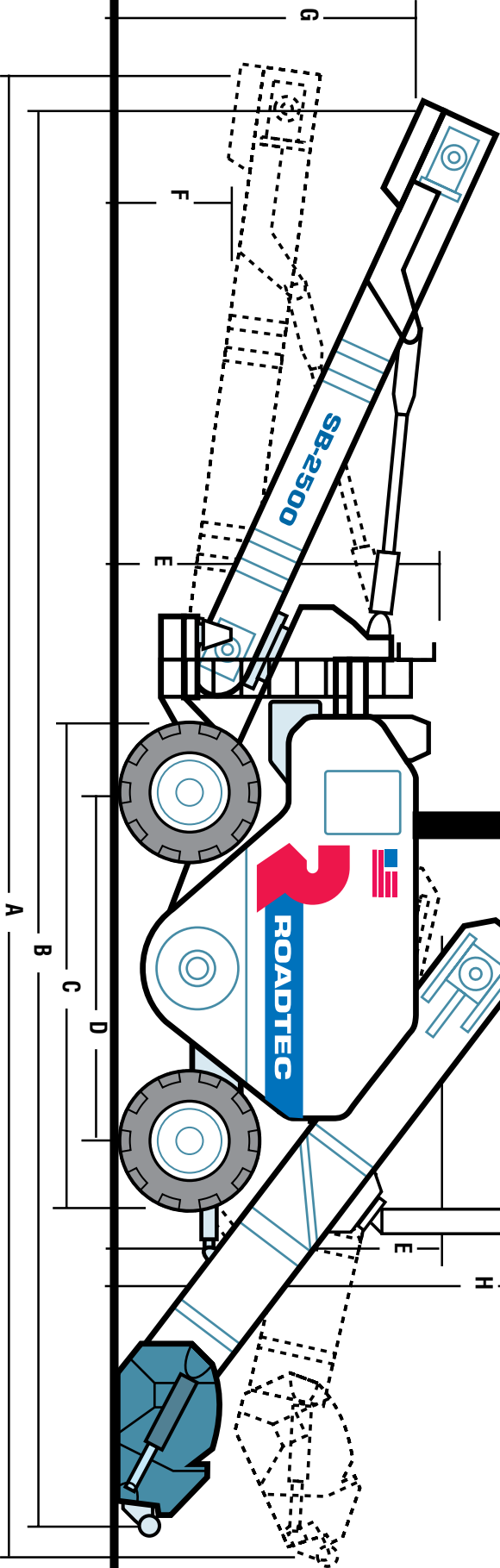

SHIPPING WEIGHT: 79,300+ lbs (35,970 kg)